

GX 390 H1 QH

MOTORES



Curva de Performance

POTENCIA

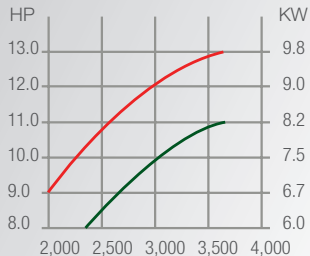

TORQUE

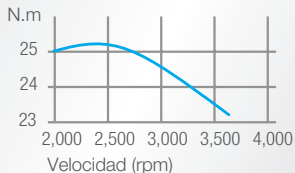

Potencia Máxima ———
 Potencia Neta ———
 Torque Neto ———

Características



Potencia Máxima (HP / rpm)	13.0 / 3,600
Potencia Neta (HP / rpm)	11.0 / 3,600
Potencia Neta en Watts (KW / rpm)	8.2 / 3,600
Torque Máximo (N.m / rpm)	26.5 / 2,500
Torque Neto (N.m / rpm)	25.2 / 2,500
Tipo de motor	4 Tiempos, OHV, Monocilíndrico
Desplazamiento	389 cc
Capacidad de tanque de combustible	6.5 L
Capacidad de aceite del motor	1.1 L
Consumo de combustible	3.7 L/h
Filtro de aire	DUAL
Dimensiones L x A x Al	405 x 450 x 443 mm
Peso en seco	31 kg

Medidas Generales

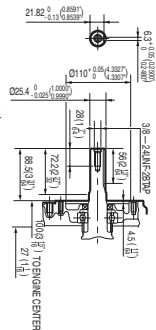
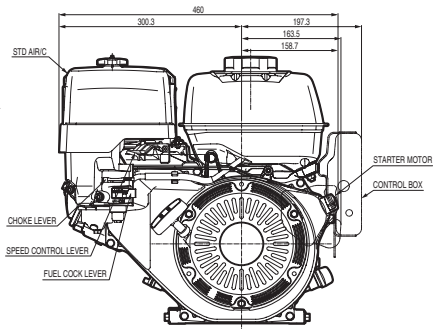
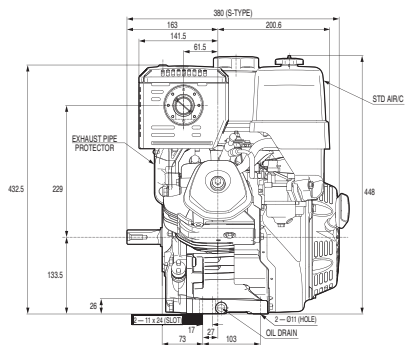

Aplicaciones

Mezcladora de concreto,
alisadora de concreto
y máquinas diversas

